

ZOC 33/64Px AND ZOC 33/64PxX2

ELECTRONIC PRESSURE SCANNING MODULE

INSTRUCTION AND SERVICE MANUAL

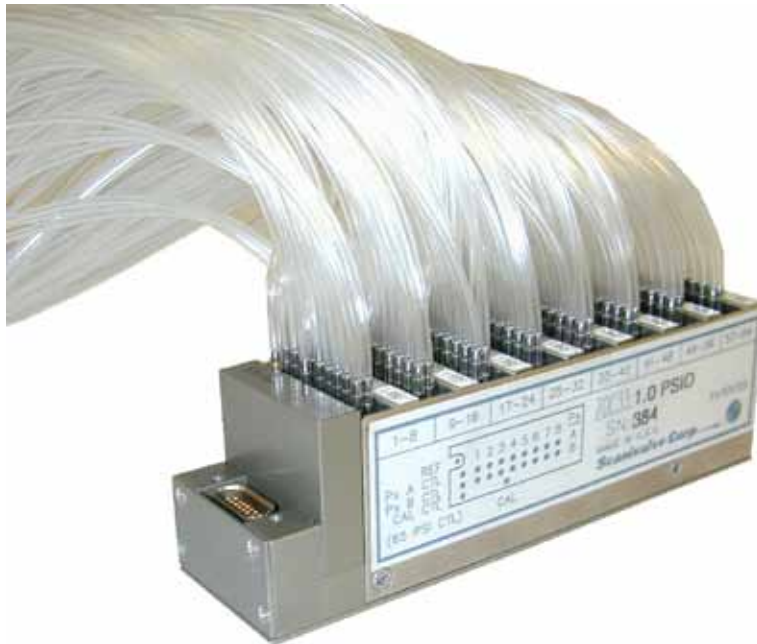

Scanivalve Corp. 

PREFACE

WARNINGS, CAUTIONS AND NOTES



The WARNING! symbol indicates that danger of injury for persons and the environment and/or considerable damage (mortal danger, danger of injury) will occur if the respective safety precautions are not taken.



The CAUTION ! symbol indicate danger for the system and material if the respective safety precautions are not taken.



The ESD note symbol indicates that proper precautions for handling Electrostatic Sensitive Devices needs to be taken when performing the related operation. This includes the use of grounded work surfaces and personal wrist straps to prevent damage to sensitive electronic components.

WARRANTY

Scanivalve Corporation, Liberty Lake, Washington, hereafter referred to as Seller, warrants to the Buyer and the first end user that its products will be free from defects in workmanship and material for a period of twelve (12) months from date of delivery. Written notice of any claimed defect must be received by Seller within thirty (30) days after such defect is first discovered. The claimed defective product must be returned by prepaid transportation to Seller within ninety (90) days after the defect is first discovered. Seller's obligations under this Warranty are limited to repairing or replacing, at its option, any product or component part thereof that is proven to be other than as herein warranted.

Surface transportation charges covering any repaired or replacement product or component part shall be at Seller's expense; however, inspection, testing and return transportation charges covering any product or component part returned and redelivered, which proves

not to be defective, shall be at the expense of Buyer or the end user, whichever has returned such product or component part.

This Warranty does not extend to any Seller product or component part thereof which has been subjected to misuse, accident or improper installation, maintenance or application; or to any product or component part thereof which has been repaired or altered outside of Seller's facilities unless authorized in writing by Seller, or unless such installation, repair or alteration is performed by Seller; or to any labor charges whatsoever, whether for removal and/or reinstallation of the defective product or component part or otherwise, except for Seller's labor charges for repair or replacement in accordance with the Warranty. Any repaired or replacement product or component part thereof provided by Seller under this Warranty shall, upon redelivery to Buyer, be warranted for the unexpired portion of the original product warranty.

THIS WARRANTY IS IN LIEU OF AND EXCLUDES ALL OTHER WARRANTIES, EXPRESS OR IMPLIED, ARISING BY

OPERATION OF LAW OR OTHERWISE, INCLUDING THE IMPLIED WARRANTIES OF MERCHANTABILITY AND FITNESS FOR A PARTICULAR PURPOSE, AND IN NO EVENT SHALL SELLER BE LIABLE FOR INCIDENTAL OR CONSEQUENTIAL DAMAGES.

In the event of a failure:

1) Notify Scanivalve Corporation, Customer Service Department. Include model number and serial number. On receipt of this information, service data or shipping instructions will be forwarded. This may be transacted by telephone or e-mail.

2) On receipt of shipping instructions, forward the product, transportation prepaid. Repairs will be made and the product returned.

3) All shipments should be made via "Best Way". The product should be shipped in the original packing container or wrapped in protective material and surrounded by a minimum of four (4) inches of a shock absorbing material.

TRADEMARKS ® AND COPYRIGHTS ©

Scanivalve is a registered trademark of Scanivalve Corporation.

All other brand and product names are trademarks or registered trademarks of their respective companies.

PACKAGING FOR SHIPMENT

If the product must be shipped, whether being returned to Scanivalve or relocated to another location it must be packaged properly to minimize the risk of damage. The recommended method of packing is to place the instrument in a container, surrounded on all sides with at least four inches of shock attenuating material such as Styrofoam peanuts.

IMPORTANT NOTICE

Please note that the product specifications and other information contained in this manual are subject to change without notice. Scanivalve Corporation makes an effort and strives to provide complete and current information for the proper use of the equipment. If there are any questions regarding this manual or the proper use of the equipment, contact Scanivalve Corporation.

CONTACT INFORMATION

If there are any questions or concerns regarding any Scanivalve product please do not hesitate to contact us at the following:

Scanivalve Corp.
1722 N. Madson Street
Liberty Lake, WA 99019
Telephone: (800)935-5151 (509)891-9970
Fax: (509)891-9481
scanco@scanivalve.com
www.scanivalve.com

Scanivalve Corporation is an ISO9001:2000 certified company.

TABLE OF CONTENTS

PREFACE	IV
Warnings, Cautions and Notes	iv
Warranty	iv
Trademarks ® and Copyrights ©	v
Packaging for Shipment	v
Important Notice	v
Contact Information	v
SECTION 1: SPECIFICATIONS	2
General Specifications	2
Environment Specifications	2
SECTION 2: INTRODUCTION	4
General Description	4
ZOC33/64Px	5
ZOC33/64PxX2	6
ZOC33/64Px - Valveless	8
Thermal Control Unit (ZOCTCU)	9
SECTION 3: INSTALLATION & OPERATION	10
Unpacking	10
Overview	10
Electrical Inputs & Outputs	10
Pneumatic Inputs	11
Calibration Valve Operation	12
ZOC33 ZOCTCU Connectors	13
Sensor Installation	14
SECTION 4: ELECTRONIC COMPONENTS	15
Amplifier Board	15
Multiplexer Board	16
Decoder Board	17

SECTION 1: SPECIFICATIONS

GENERAL SPECIFICATIONS

Size (WxHxD)	1.43" x 1.69" x 4.98" (36.42cm x 42.8cm x 126.37cm)		Resolution	infinite
Weight			Inputs (Px)	64 or 128 (PxX2)
ZOC33/64Px	11 oz (312g)		Pneumatic Connectors	
ZOC33/64PxX2	13 oz (369g)		ZOC Px	.042" tubulations
ZOC33TCU (including ZOC33 module)	4.0 lbs (1.8kg)		ZOC Control Pressures	0.063" tubulations
			ZOCTCU	1-2 73 port connectors (73ZOCM-063)
Full Scale Ranges	±10 inH ₂ O, ±20 inH ₂ O, 1psid, 2.5psid, 5psid, 15psid and 50psid (2.5kPa, 5kPa, 7kPa, 17kPa, 35kPa, 100kPa, and 350kPa)		Electrical Connectors	
			ZOC Module	15 pin MDM 15SL2P
			ZOCTCU	MS3100A Type, Size 20
Accuracy (after calibration)			Power Requirements	
10 inH ₂ O	±0.15% FS		ZOC33 Module	+15Vdc @ 120mA
20 inH ₂ O	±0.12% FS		ZOCTCU	-15Vdc @ 30mA
1psid	±0.10% FS			+24VDC @ 1.0A
2.5psid	±0.10% FS		Full Scale Output	
5psid	±0.08% FS		Standard	±2.5Vdc
15psid	±0.08% FS		Optional	±5.0Vdc
50psid	±0.08% FS		Sensor Excitation	+5Vdc Constant Voltage (Internally Supplied)
Overpressure (No damage)			<u>ENVIRONMENT SPECIFICATIONS</u>	
10 inH ₂ O	5psi		Operating Temperature	0 to 60 °C
20 inH ₂ O	5psi		Humidity	
1psid	5psi		Operation	5 to 95% RH, Non-Condensing
2.5psid	200%		Storage	5 to 95% RH, Non-Condensing
5psid	200%		Shock & Vibration	
15psid	200%		Shock	MIL-STD-810D Curve H
50psid	200%		Vibration	10G
Temperature Sensitivity			Acceleration	10G
Range	Zero	Span	Media	Gasses compatible with Silicon, Silicone, Aluminum and Buna-N
10 inH ₂ O	0.25%	0.10%		
20 inH ₂ O	0.25%	0.08%		
1psid	0.10%	0.05%		
2.5psid	0.10%	0.05%		
5psid	0.10%	0.05%		
15psid	0.10%	0.05%		
50psid	0.10%	0.05%		
Max Reference Pressure	50 psig (350kPa)			
Scan Rate	40kHz (standalone)			

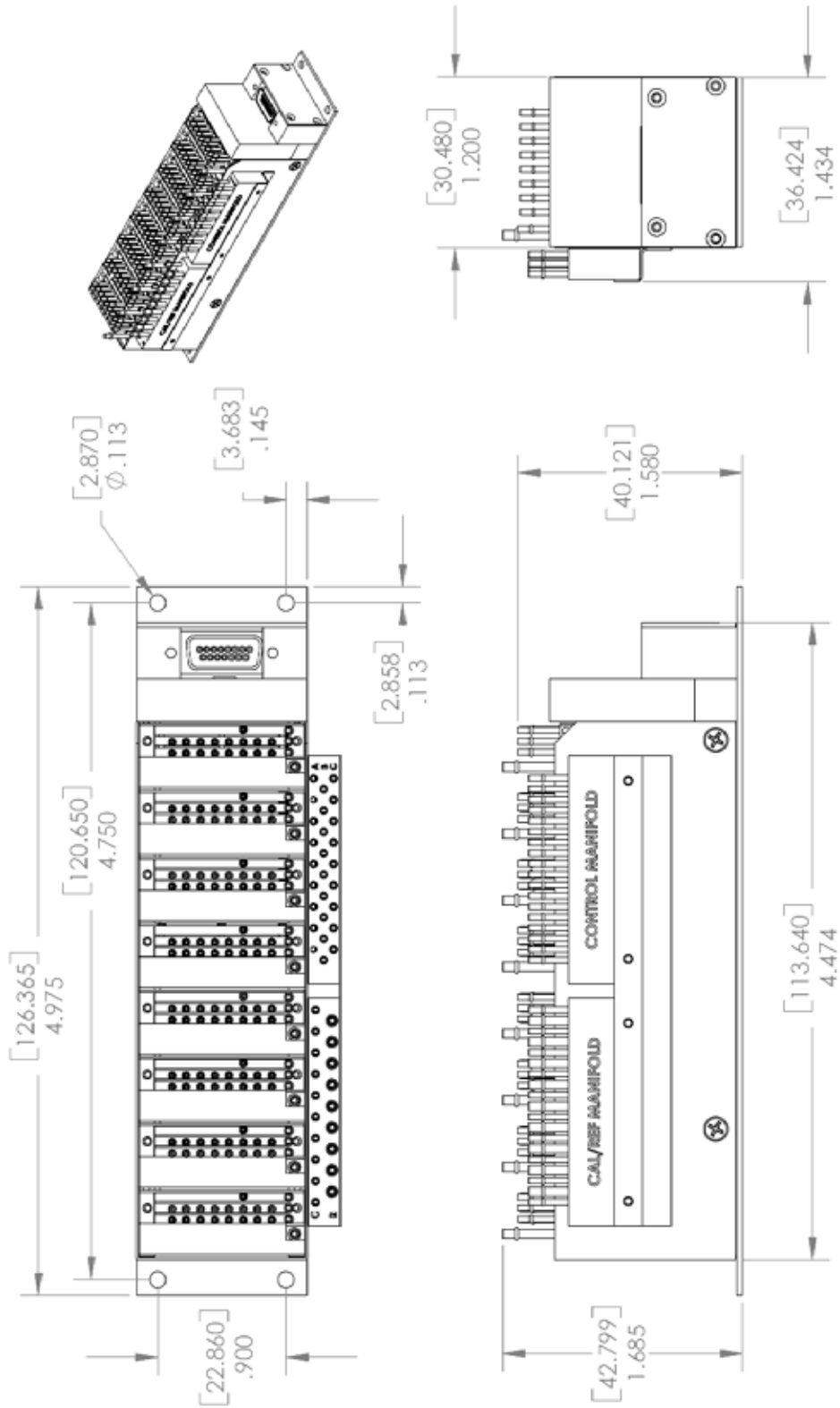

FIGURE 1.1 - ZOC33/64PXX2 DIMENSIONS [INCHES(MM)]

SECTION 2: INTRODUCTION

GENERAL DESCRIPTION

The ZOC33 is an electronic pressure scanner which can accept up to 128 pneumatic inputs. Each ZOC33 module incorporates 64 individual piezoresistive pressure sensors. Each eight pressure sensors are manufactured in a housing designed to facilitate field replacement. No special tools are required to access the sensors. The ZOC33 electronic pressure scanning module is specifically designed for use in wind tunnels, flight tests or applications where space is at a premium and pressures will not exceed 50 psi.

The ZOC33 is powered by $\pm 15\text{Vdc}$. The module is manufactured in a 64 channel model, a 128 channel duplexed model and a 64 channel valveless model. All models are available in multiplexed versions only.

The ZOC33 pressure sensors are arranged in blocks of 8. In all variations except the valveless model, each block of eight sensors has its own individual calibration valve. This valve had four modes of operations:

- (1) Operate
- (2) Calibrate
- (3) Purge
- (4) Isolate

The modes are selected by applying control pressures in a predetermined and logical order. The ZOC33 calibration valves utilizes valve logic where the valve defaults to the purge mode when no control pressures are applied.

Beginning with serial number 144, all ZOC33 modules have a 500 ohm platinum RTD installed. This RTD is used by a DSM3000/3200/3400 module or RAD3200/4000 module to determine the temperature of the ZOC33 module. This feature will be added to any older ZOC33 module received for repairs.

Beginning with serial number 390, all ZOC33 modules have a TEDS ID chip installed and programmed to interface with a RAD3200/4000 or DSM3400 pressure measuring system. This feature will be added to all older ZOC33 modules received for repair.

Beginning with serial number 399, the ZOC33 valves were redesigned. This results in a small change to the module dimensions. This change only applies to valved models. A ZOC33 valved model that requires repairs to the valves will have to be upgraded to the newest configuration.

ZOC33/64Px

This module contains sixty four (64) pressure sensors in eight sensor packs. Each sensor pack contains:

- eight sensors
- a calibration valve
- an excitation board
- a high speed multiplexer

The output of each sensor is directed to the multiplexer/ amplifier. The channel to be output is selected by a CMOS level binary address supplied by either a Scanivalve data acquisition system or by the customer’s data acquisition system.

Figure 2.1 depicts a ZOC33/64Px.

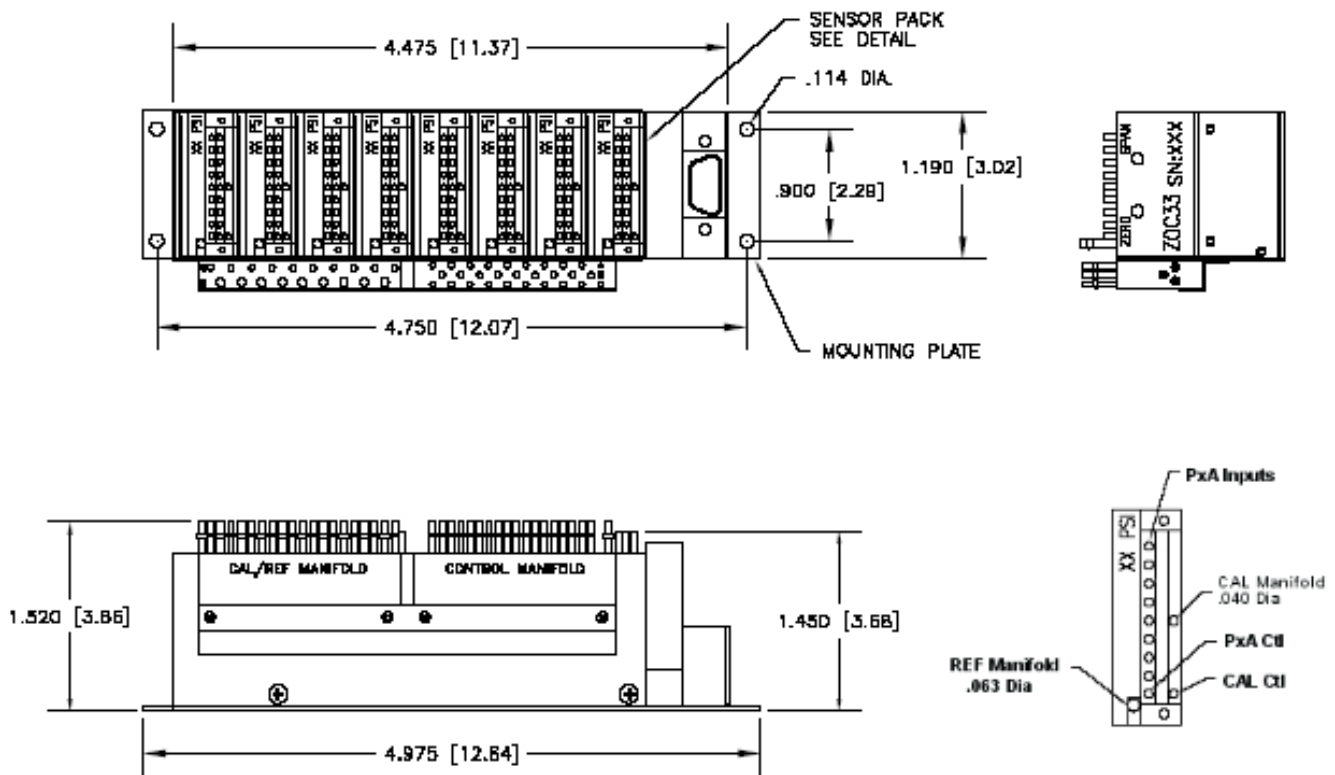

FIGURE 2.1 - ZOC33/64Px DIMENSIONS [INCHES(CM)]

ZOC33/64PxX2

This module contains sixty four (64) pressure sensors in eight sensor packs. Each sensor pack contains:

- eight sensors
- a calibration valve
- a duplexing valve
- an excitation board
- a high speed multiplexer
- 16 input tubes (Bank A and Bank B, 8 inputs each)

The sensors are arranged in eight groups of eight. Each sensor has two pneumatic inputs: Bank A and Bank B. The inputs are switched pneumatically by enabling the duplexing valve. Even though there are 128 pressure inputs only one Bank of 64 pressure inputs can be measured at one time. Each group of eight sensors may be a different range. The standard output of the module is $\pm 2.5\text{Vdc}$ corresponding to the channel selected by a CMOS level 6 bit binary address.

Figure 2.2 depicts a ZOC33/64PxX2, Serial number 398 and earlier.

Figure 2.3 depicts a ZOC33/64PxX2, Serial number 399 and later.

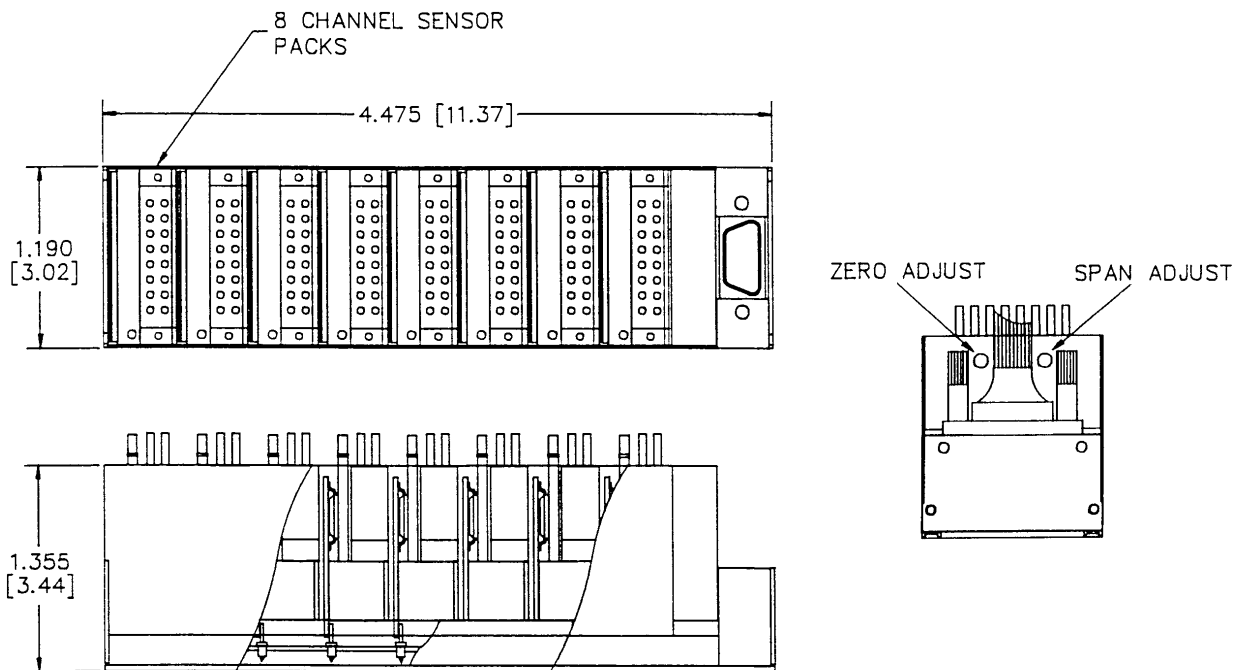

FIGURE 2.2 - EARLY ZOC33/64PxX2 DIMENSIONS [INCHES(CM)]

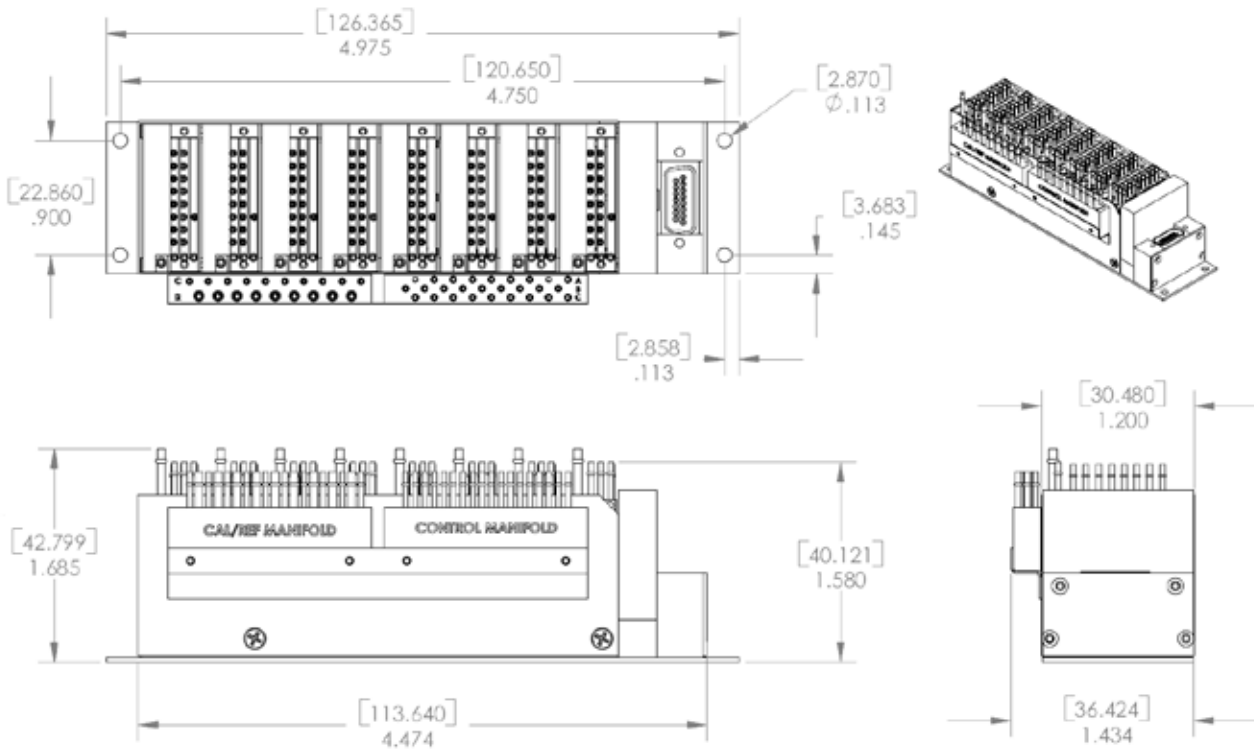

FIGURE 2.3 - CURRENT ZOC33/64PXX2 DIMENSIONS [INCHES(MM)]

ZOC33/64Px - VALVELESS

This module contains sixty four (64) pressure sensors in eight sensor packs. Each sensor pack contains:

- eight sensors
- an excitation board
- a high speed multiplexer

The output of each sensor is directed to the multiplexer/amplifier. The channel to be output is selected by a CMOS level binary address supplied by either a Scanivalve data acquisition system or by the customer's data acquisition system.

This version does not have a calibration valve. All calibrations are performed using the reference port. In wind tunnel applications, a zero offset correction is performed "wind off." The valveless design is also preferred for rotating applications as no control pressures are required.

Figure 2.4 depicts a ZOC33/64Px Valveless.

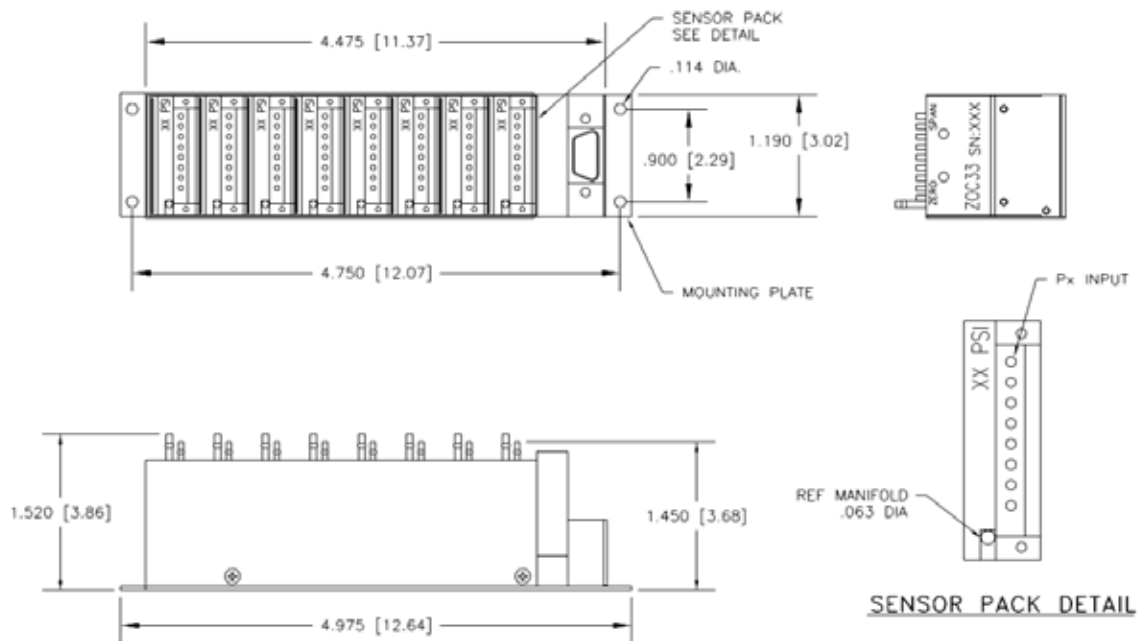

FIGURE 2.4 - ZOC33/64Px VALVELESS DIMENSIONS [INCHES(CM)]

THERMAL CONTROL UNIT (ZOCTCU)

An optional Thermal Control Unit (ZOCTCU) (Figure 2.5) is available for applications where temperature swings may be great enough to exceed the compensated range of the sensors. Exceeding the compensated temperature range can induce errors in the pressure measurements. See Section 1, **Specifications** for more information on the compensated temperature range. The ZOCTCU consists of a housing, insulation and a proportional heater which will maintain the temperature for the module at $40^{\circ}\text{C} \pm 0.3^{\circ}\text{C}$.

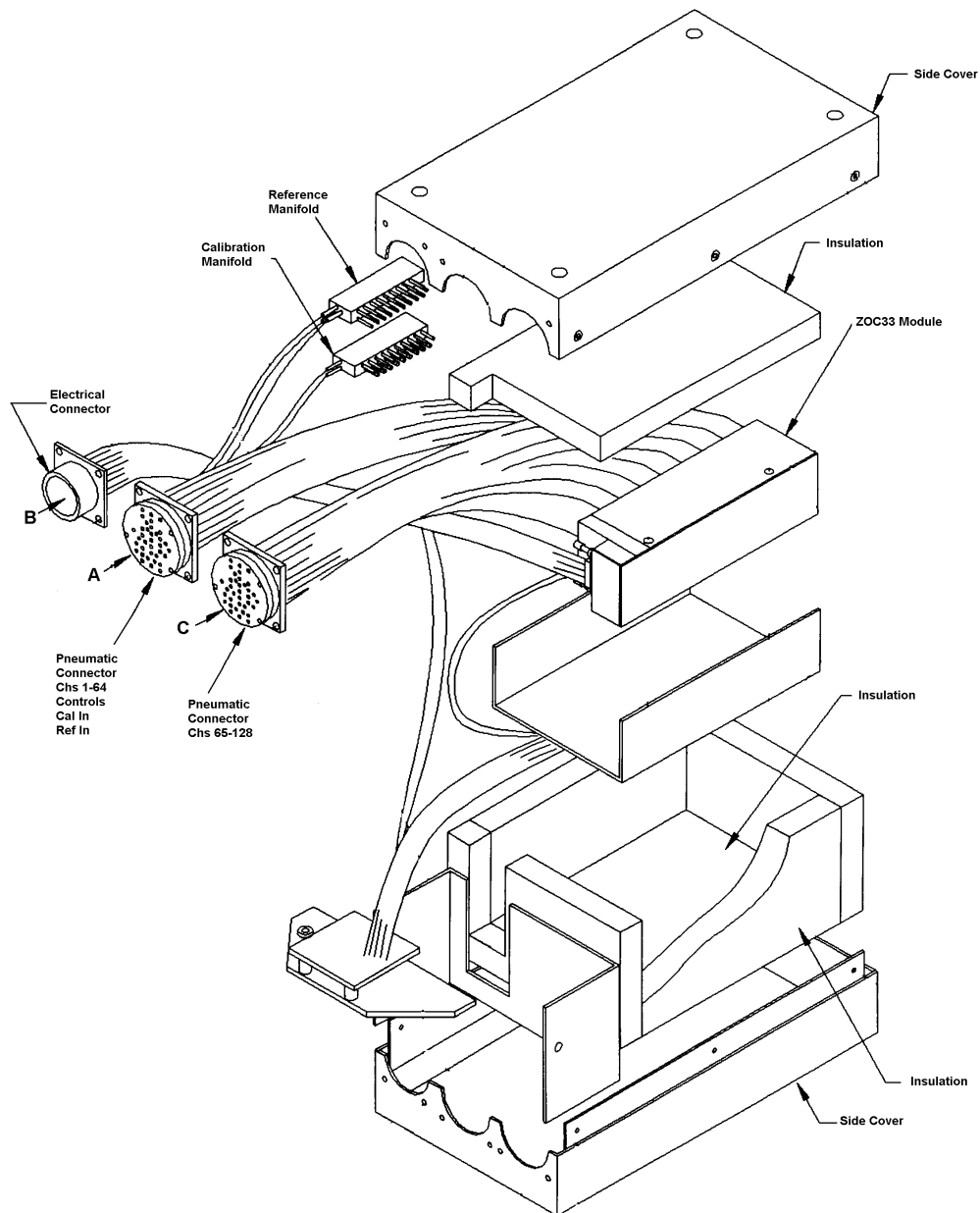

FIGURE 2.5 - ZOC33 THERMAL CONTROL UNIT (128 CHANNEL SHOWN)

SECTION 3: INSTALLATION & OPERATION

UNPACKING

All ZOC33 modules have been extensively tested prior to shipment. All modules are packed to minimize the chances of shipping damage. However, damage can still occur. The customer must inspect the modules and shipping materials for obvious signs of damage. If it is suspected that damage may have occurred, contact Scanivalve Corporation immediately.

Once you have unpacked the module, do an inventory check of the shipment. Each shipment should at least include a mating connector and this manual.

OVERVIEW

ZOC33 modules are designed to function best when used with one of Scanivalve Corporation's data acquisition systems, either a DSM3000/3200/3400 or RAD3200/4000. All ZOC33 modules will function with older data acquisition systems such as HyScan 2000/1000 as well. They can also be used as a standalone module with another high speed data acquisition system.

ELECTRICAL INPUTS & OUTPUTS

The Electrical Input and Output wiring is compatible with

all other ZOC cable serviced modules. The ZOC33 may be installed into existing HyScan systems without changing configurations.

The user is cautioned to follow safe instrument handling practices when handling the ZOC33 modules. This includes:

- (1) Make and break all connections to the module with the power off.
- (2) Recommended power input to the module is $\pm 15\text{Vdc}$.

Figure 3.2 shows the output connector pin assignments for all of the ZOC33 variations. This figure shows the RTD connections (+Tem and -Temp) and the TEDS ID chip output (ID). These connections may not be active on all modules. Refer to Section 2, **Introduction** for more information.



CAUTION! Not following standard safe instrumentation handling practices could permanently damage the modules.

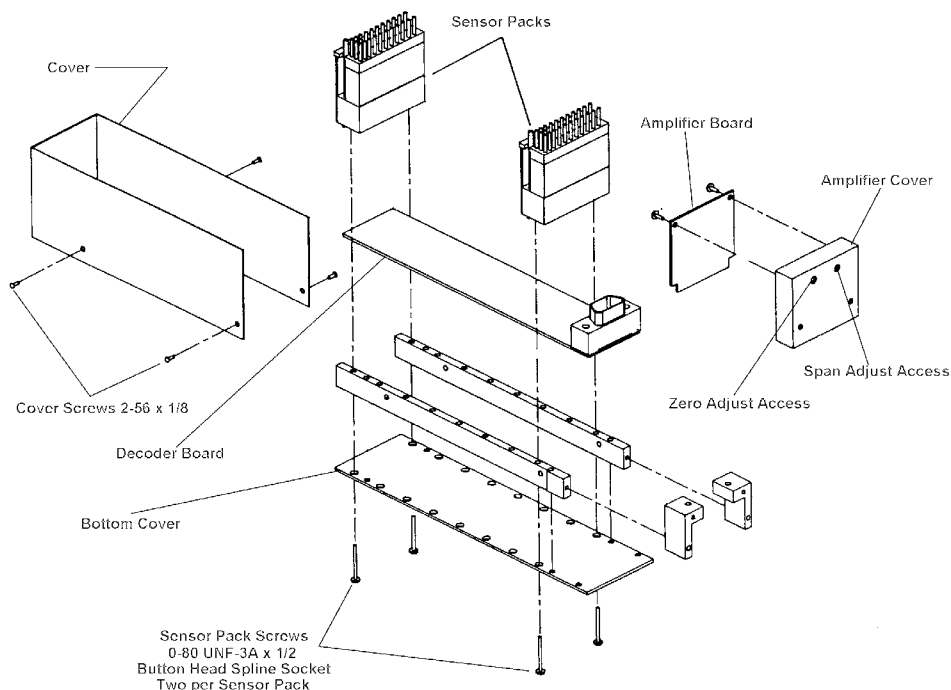

FIGURE 3.1 - ZOC33/64Px EXPLODED VIEW

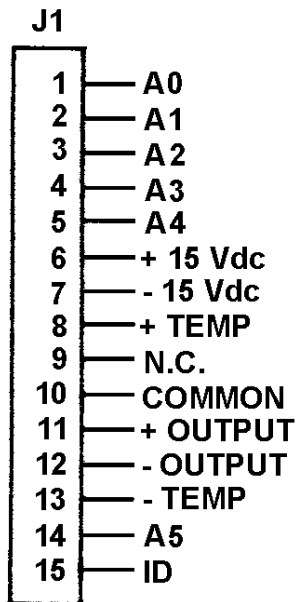

FIGURE 3.2 - ZOC33 INPUT/OUTPUT CONNECTOR

PNEUMATIC INPUTS

Pneumatic inputs consist of: Px Inputs(8 or 16), Control Pressure Inputs (PxA Ctl, Cal Ctl), a Calibration Input, and a Reference Input. The duplex version also has a duplex control pressure input (PxB). Valveless units do not have Control Pressure and Calibration Inputs

All Px inputs are .040 inch(1.067mm) bulged tubulations. These tubulations are designed to accept any .042 inch tubing manufactured by Scanivalve Corp. Each sensor pack valve block contains eight (8) or, in the duplex version, sixteen(16) Px inputs. ZOC33 modules are capable of measuring pressures up to 50 psid.

Control pressure inputs consist of: PxA CTL and CAL CTL. The duplex module has a third control pressure input, PxB CTL. These inputs are used to switch the valve logic to each of the four (4) states: Operate, Calibrate, Purge, and Isolate. The control pressures must be 65 psi. Figure 3.3 shows the 64Px valve logic. Figure 3.4 shows the 64PxX2 Valve Logic.

Calibration/Reference Inputs consist of a Calibration input and a Reference input. The Calibration input is an .042 inch O.D. tubulation. It is normally connected to a source of calibration pressures. Internally, this input is manifolded to all of the sensors through the calibration valving. The Reference input is an .063 inch (1.6mm)O.D. tubulation. It provides a point of reference for the transducers. All of the sensors in each block of eight share a single reference.

Manifold blocks are provided with the module to facilitate plumbing. This also permits easy removal of a sensor pack in the event that field repairs are required.

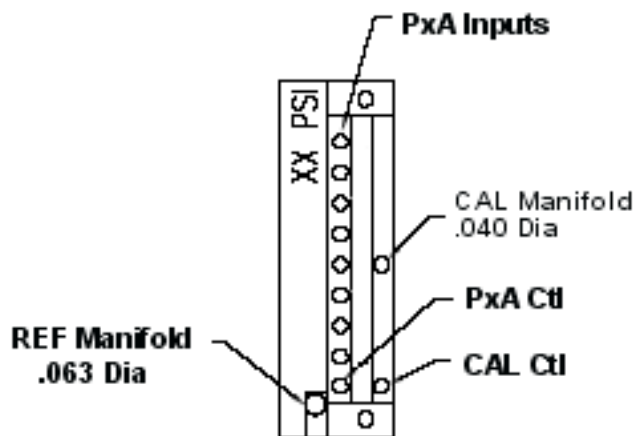

FIGURE 3.3 - ZOC33/64Px PNEUMATIC INPUTS

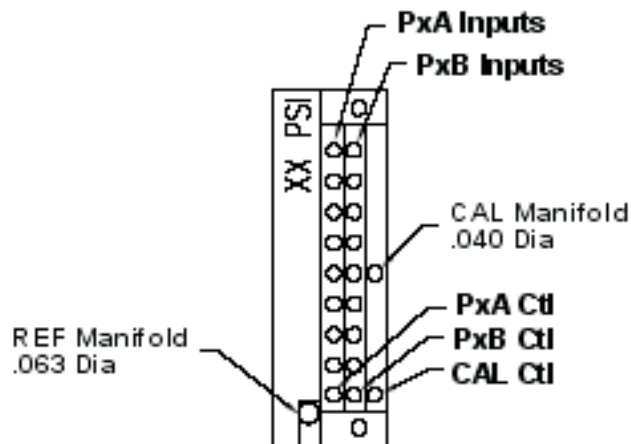

FIGURE 3.4 - ZOC33/64PxX2 PNEUMATIC INPUTS

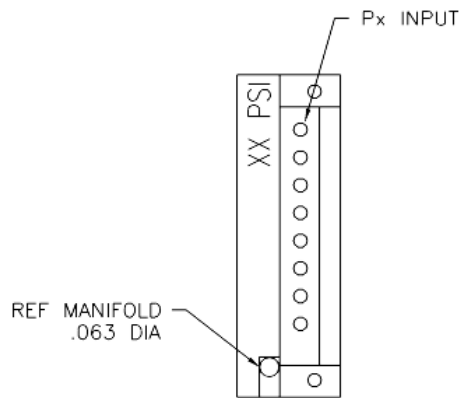

FIGURE 3.5 - ZOC33/64Px VALVELESS PNEUMATIC INPUTS

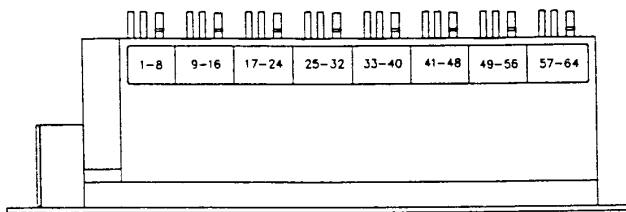

FIGURE 3.6 - ZOC33 CHANNEL IDENTIFICATION

CALIBRATION VALVE OPERATION

As discussed in Section 2, Introduction, ZOC33/64Px and ZOC33/64PxX2 modules are equipped with an internal calibration valve in each sensor pack. The calibration valve can take one of four states:

It is important that all control pressures should be dry, filtered instrument air or nitrogen.

Operate Mode

This connects each Px input to its associated pressure sensor. The ZOC33/64PxX2 module allows the customer to select one of two banks for input.

Calibrate Mode

This mode connects all the pressure sensors to the calibration input.

Purge Mode

This mode connects the Px inputs to the pressure sensors and the calibration input. A safe purge pressure can be applied to purge input lines.

Isolate Mode

This mode isolates the pressure sensors from the Px and calibration lines.

Tables 3.1, 3.2 and 3.3 are state tables that describe pneumatic logic for each state of the valves.

Table 3.1 - ZOC33/64Px Valve Logic		
Mode	Px CTL	CAL CTL
Operate	X	65psi
Calibrate	65psi	X
Purge	X	X
Isolate	65psi	65psi

Table 3.2 - ZOC33/64PxX2 Valve Logic			
Mode	PxA CTL	PxB CTL	CAL CTL
Operate A	X	65psi	65psi
Operate B	65psi	X	65psi
Calibrate	65psi	65psi	X
Purge	X	X	X
Isolate	65psi	65psi	65psi

Table 3.3 - ZOC33/64Px Valveless Valve Logic		
Mode	Px CTL	CAL CTL
Operate	X	X
Calibrate	N/A	N/A
Purge	N/A	N/A
Isolate	N/A	N/A

NOTE: Valveless Modules do not have control pressure inputs

ZOC33 ZOCTCU CONNECTORS

Figure 3.7 shows the pneumatic and electrical connectors on a ZOC33 ZOCTCU. View B shows the electrical connector, View A shows the pneumatic connector for inputs 1-64, control pressures, the reference input and the calibration inputs. View C shows the pneumatic inputs for channels 65-128. This connector is not installed on a non-duplexed module. The drawing has been modified from the actual configuration for clarity.

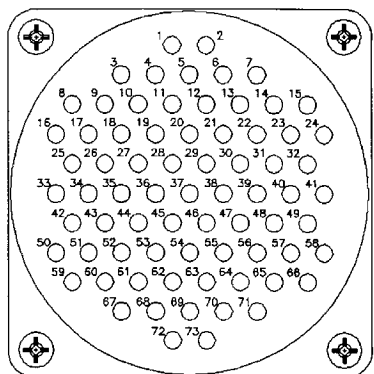

VIEW C

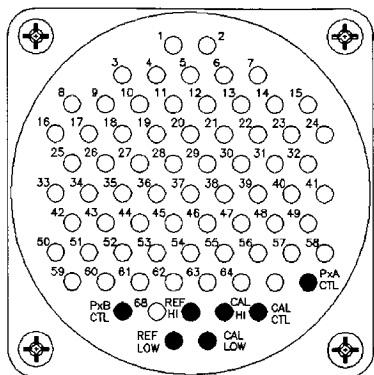

VIEW A

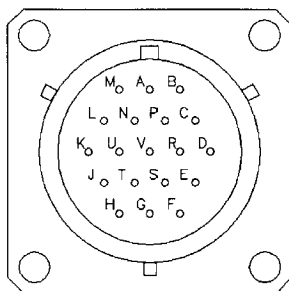

VIEW B

FIGURE 3.7 - ZOC33 ZOCTCU CONNECTORS

Table 3.4 - ZOCTCU Pneumatic Inputs			
Channels	Connector	Tubes	Notes
1-64	View A	1-64	
PxA CTL	View A	PxA CTL	
PxB CTL	View A	PxB CTL	PxB is not connected in a non-duplexed module
CAL CTL	View A	CAL CTL	
CAL HI	View A	CAL HI	
CAL LOW	View A	CAL LOW	
REF HI	View A	REF HI	
REF LOW	View A	REF LOW	
1-64	View C	1-64	This connector is only installed for duplex modules

Table 3.5 - ZOCTCU Electrical Inputs/Outputs		
Pin	Function	Notes
A	Address 0	
B	Address 1	
C	Address 2	
D	Address 3	
E	Address 4	
F	+15Vdc	
G	-15Vdc	
H	+ Temp	ZOC33 Internal RTD
J	- Temp	ZOC33 Internal RTD
K	±15Vdc Return	
L	+ Output	±2.5Vdc Nominal
M	- Output	
P	+ Temp (Heater)	Heater Temperature - Pre March 2000 only
R	ID	TEDS Chip information
S	Address 5	
T	- Temp (Heater)	Heater Temperature - Pre March 2000 only
U	+28Vdc	Heater Power
V	+28Vdc Return	

SENSOR INSTALLATION

The sensors used in a ZOC33 module are piezoresistive. They are a standard Scanivalve Corporation "S-sensor". They are mounted in chip carriers which are then installed in 8-channel sensor packs. The sensor packs are field replaceable with standard hand tools. Replacing a sensor in the field is possible but not recommended without prior training from Scanivalve. If a sensor must be replaced, follow these instructions.



CAUTION! ESD PROTECTION REQUIRED. The proper use of grounded work surfaces and personal wrist straps are required when coming into contact with exposed circuits to prevent static discharge from damaging sensitive electronic components.



CAUTION! Failing to carefully follow this procedure could permanently damage the modules.

To replace a sensor, follow this procedure:

- (1) Remove appropriate sensor pack assembly from the ZOC33 (screws for each sensor pack are located at the base of the module).
- (2) If necessary, remove the valve from the sensor housing. This should be done only if tubing restrictions do not allow the sensor pack to be pulled.
- (3) Remove the sensor screw access plate. **DO NOT REMOVE O-RINGS.**
- (4) Remove the PC board.
- (5) Loosen the sensor hold down screw. **DO NOT REMOVE THE SCREW OR O-RING.**
- (6) Carefully remove the damaged sensor. Take care not to damage the wire bonds.

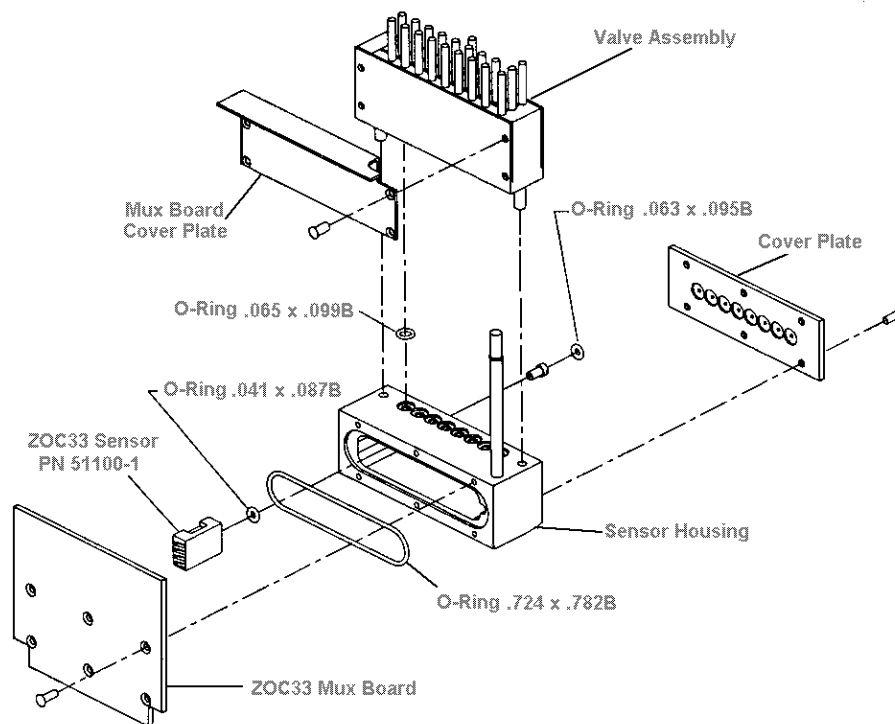

FIGURE 3.8 - ZOC33 SENSOR PACK EXPLODED VIEW

SECTION 4: ELECTRONIC COMPONENTS

AMPLIFIER BOARD

The amplifier board receives a millivolt input from the channel selected by the multiplexer. The signal is amplified to a nominal 2.5 Vdc full scale and output through the decoder board to the I/O connector. The amplifier gain is set by selecting R1 to match the average output of the sensors. The amplifier (INA110) has a settling time of 20 microseconds which means that the module channels can be scanned at 40 kHz in a “stand-alone” configuration. Gain and zero adjustments are provided to permit the user to better match the ZOC33 to a non-HyScan system (Figure 4.1). This circuit also receives an input from an RTD mounted on the Decoder Board. The RTD circuit provides a feedback to the amplifier that increases the gain by approximately 0.2%/°C. This will compensate for the 0.2%/°C decrease in output inherent in piezoresistive sensors.

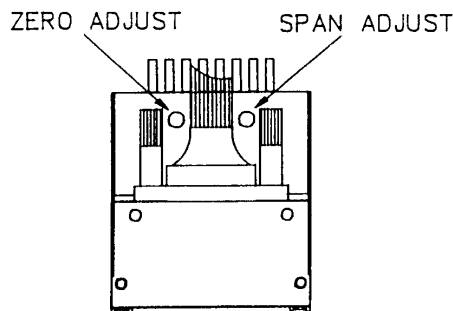

FIGURE 4.1 - ZERO AND SPAN ADJUSTMENTS



CAUTION! Adjusting the Zero and Span adjustments will invalidate any current calibration coefficients for the module.

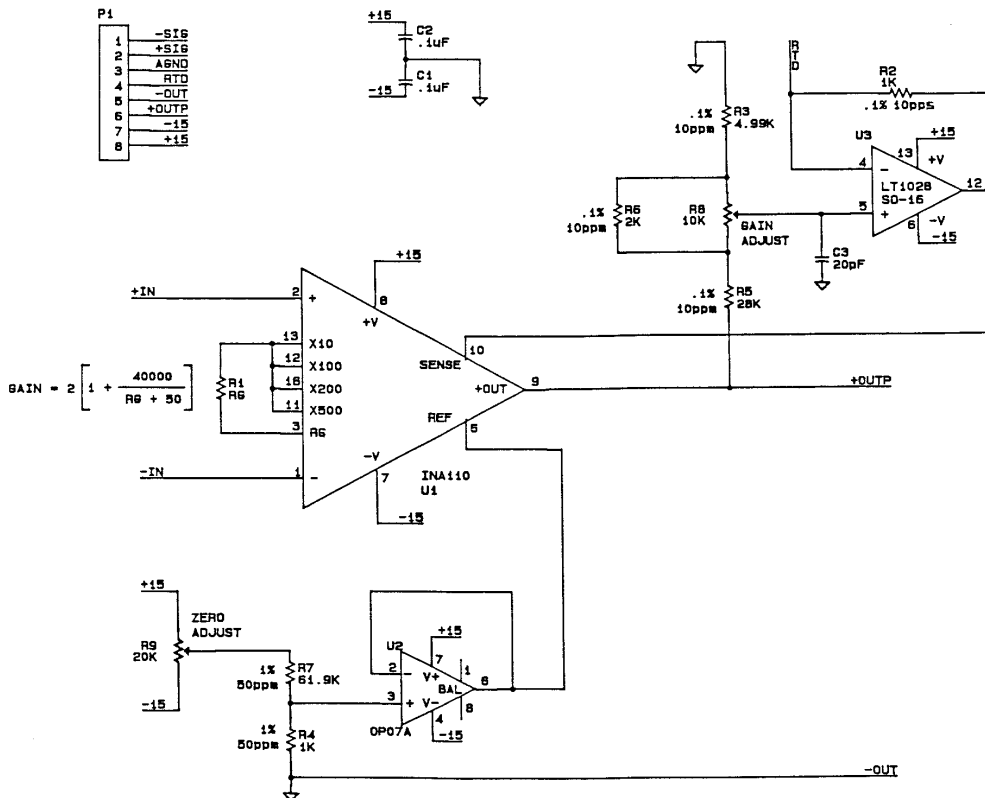

FIGURE 4.2 - ZOC33 AMPLIFIER BOARD SCHEMATIC

MULTIPLEXER BOARD

Each eight (8) channel sensor pack has its own combination multiplexer and excitation board. The board consists of a precision voltage regulator, eight sensor mounts, and a multiplexer. The board is installed on the sensor housing (Figure 3.8).

The board is powered by ±15Vdc. This voltage must be regulated, but does not need to be “instrumentation quality”. The precision voltage regulator is an LT1021 which converts the ±15Vdc to a precision 5.00Vdc. The LT1021 has a very tight output voltage tolerance and a very low temperature coefficient. The output of the LT1021 is used as an excitation voltage for the sensors.

The multiplexer receives millivolt input signals from each of the sensors. It also receives inputs from the decoder board which select the channel to be output to the amplifier board. The multiplexer is a DG507. It has a settling time of 400 nanoseconds.

The Multiplexer board plugs into the decoder board.

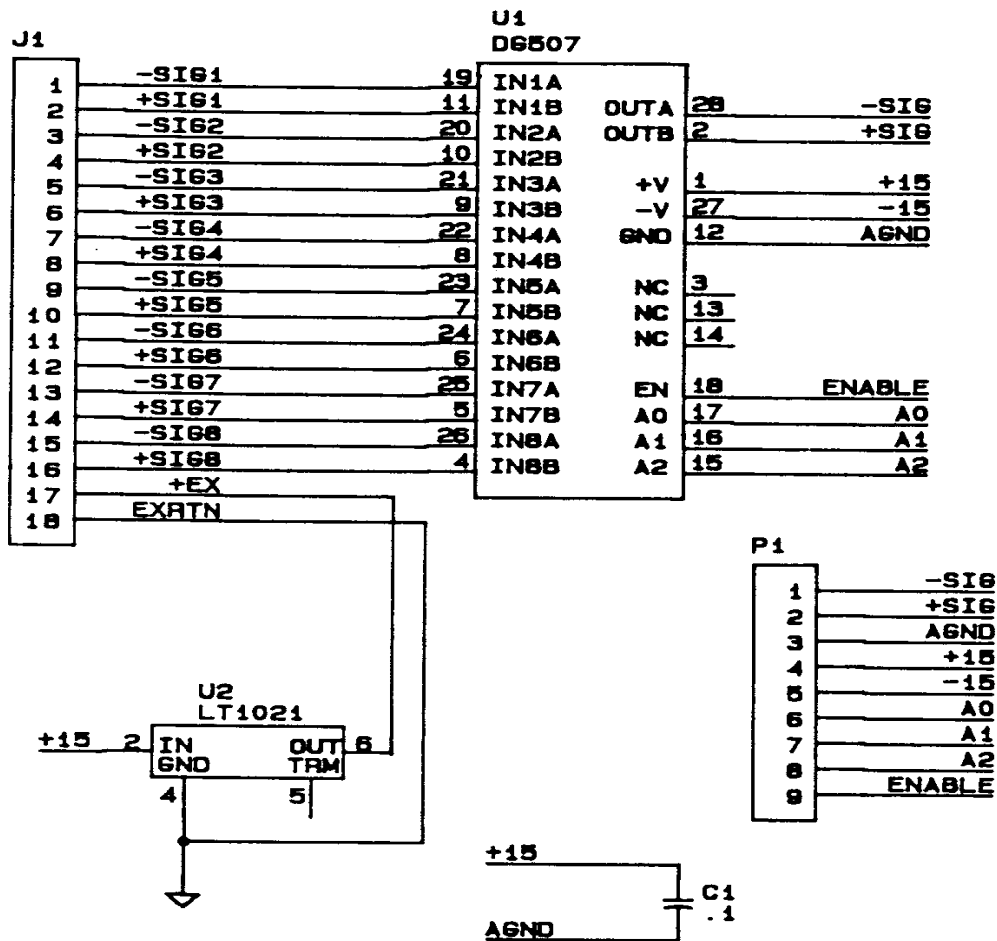

FIGURE 4.3 - ZOC33 MULTIPLEXER BOARD SCHEMATIC

DECODER BOARD

The decoder board is the main circuit board in the ZOC33. All of the sensor packs and the amplifier plug into this board. The decoder board receives the inputs from the data system and converts them into signals to drive the sensor packs.

The data system outputs an address for a channel to be read. The address is sensed by the decoder board and converted to an address and enable output. The enable line selects the sensor pack and the address line selects the channel in that pack. The signal output of that sensor is then input to the amplifier board, amplified and routed back through the decoder board to the I/O connector.

Address lines A0 through A5 are routed from the I/O connector to two 4042 latches which convert the address input to a 3 bit channel address and a one of eight enable. A channel in the module is selected by the following:

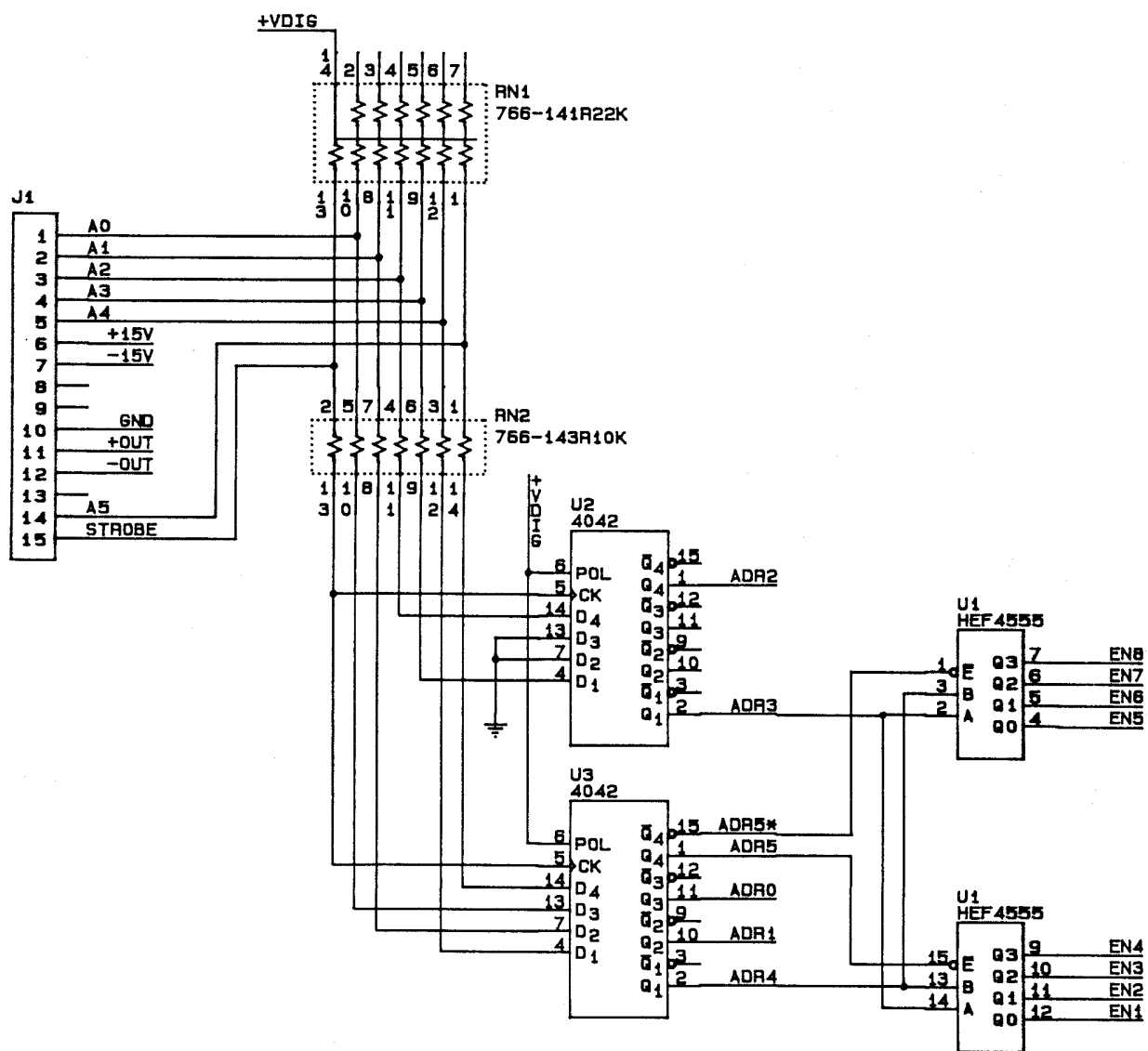

FIGURE 4.4 - ZOC33 DECODER BOARD SCHEMATIC

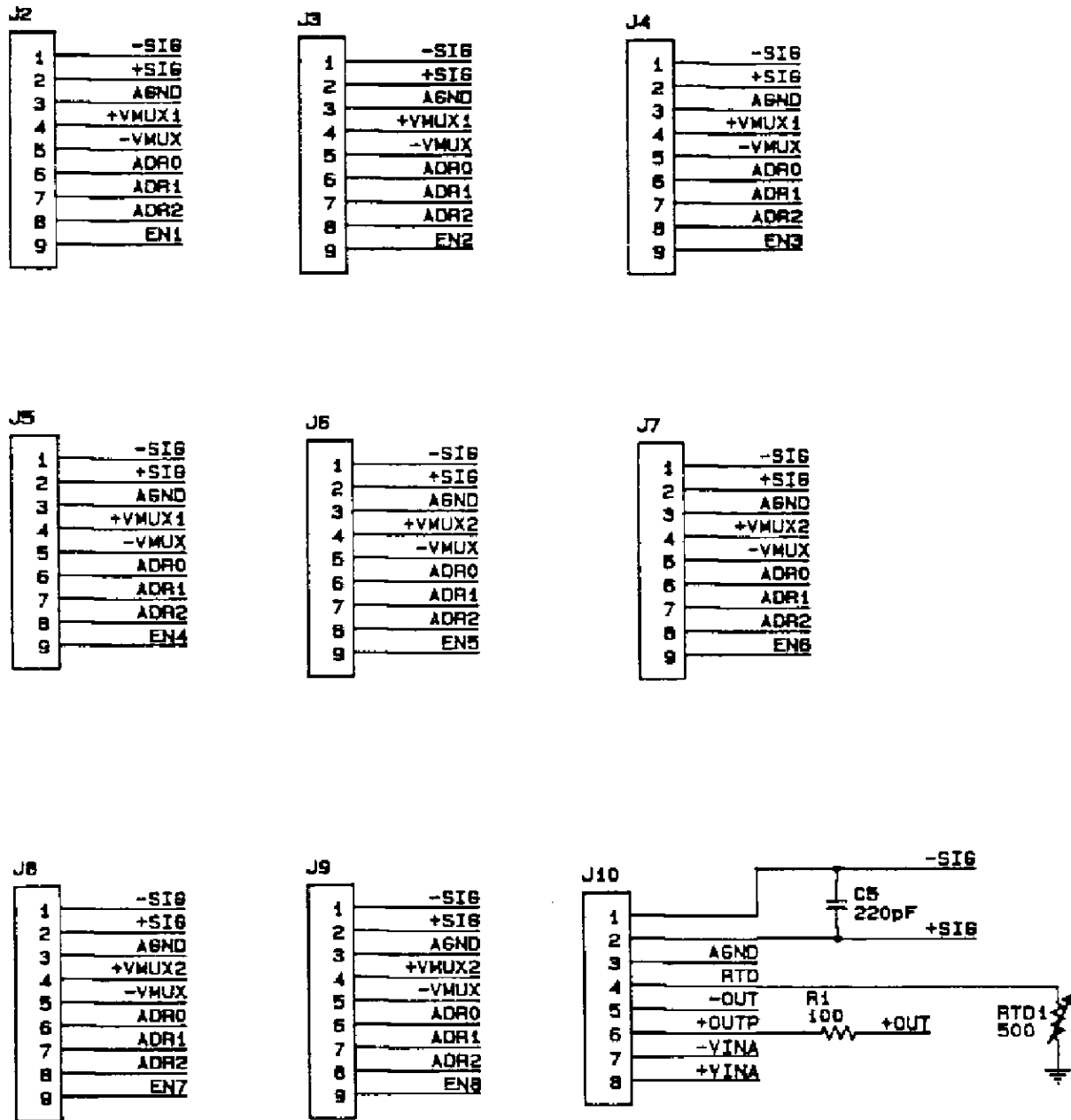

FIGURE 4.5 - ZOC33 DECODER BOARD CONNECTOR PINOUTS

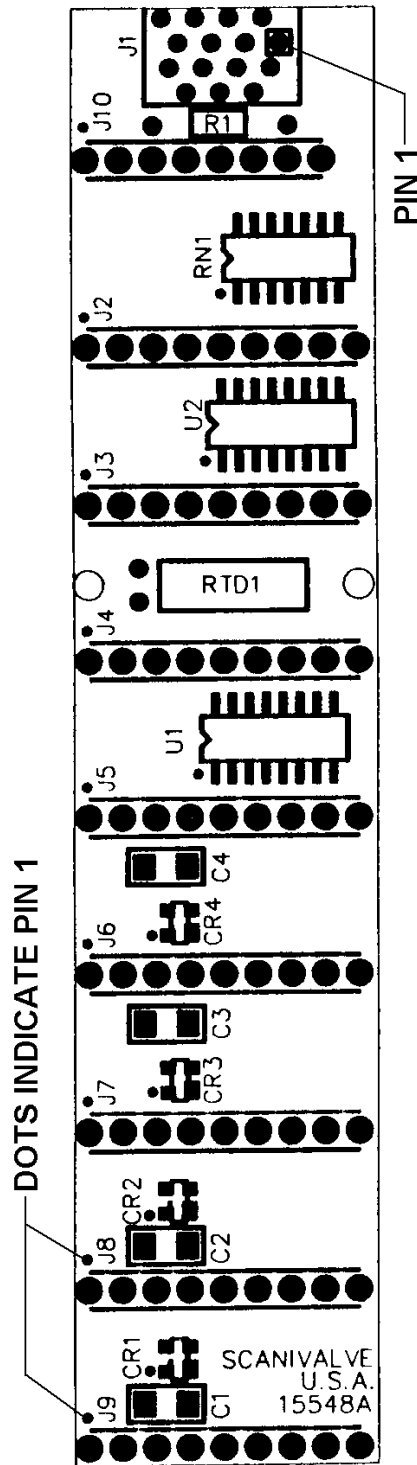

FIGURE 4.6 - ZOC33 DECODER BOARD LAYOUT

Scanivalve Corp. 
1722 N. MADSON ST.
LIBERTY LAKE, WA 99019

PHONE: 1-800-935-5151
1-509-891-9970
FAX: 1-509-891-9481

SCANCO@SCANIVALVE.COM
WWW.SCANIVALVE.COM

ZOC33 SERVICE MANUAL
JULY, 2010